

## technologia nagrań wybranych instrumentów

perkusja:

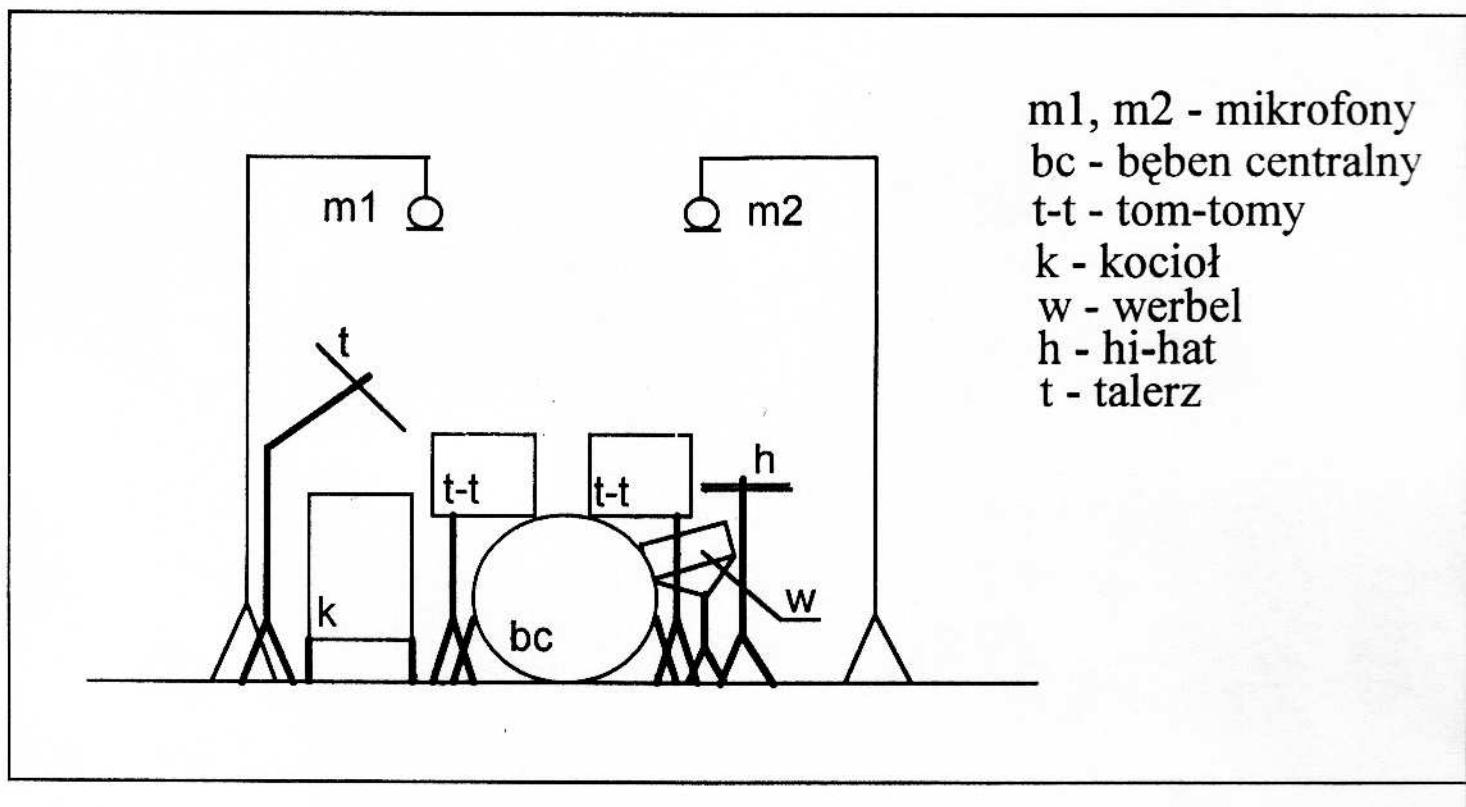



m1 - mikrofon stereof.  
pojemnościowy  
bc - bęben centralny  
t-t - tom-tomy  
k - kocioł  
w - werbel  
h - hi-hat  
t - talerz  
md1,2 - mikrofony  
dynamiczne

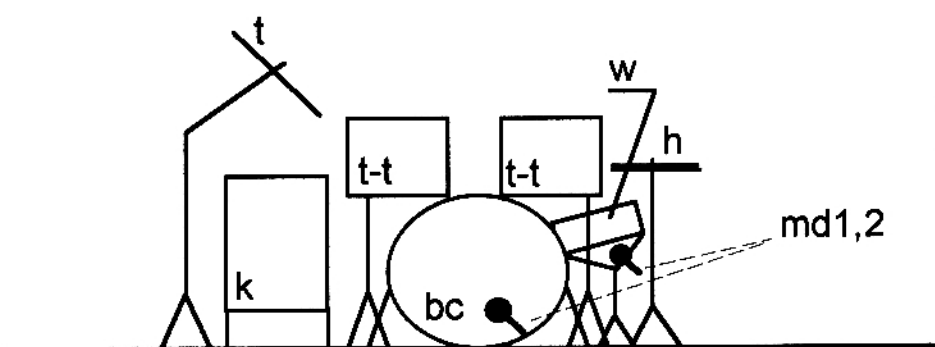

bębny jak na poprz. rysunkach  
m1,...,m7 - mikrofony  
dynamiczne

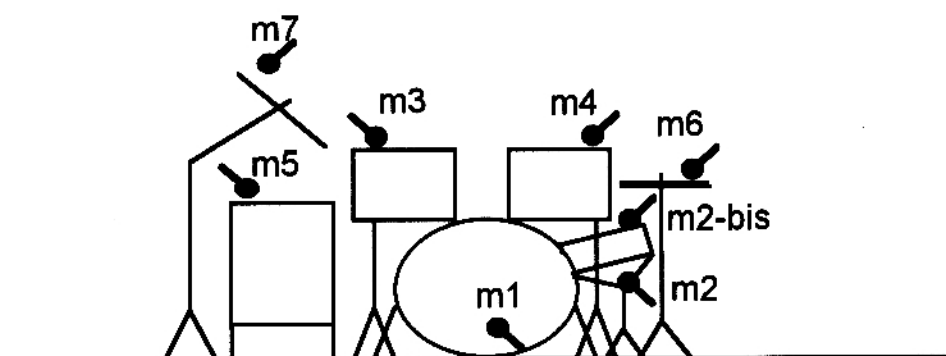

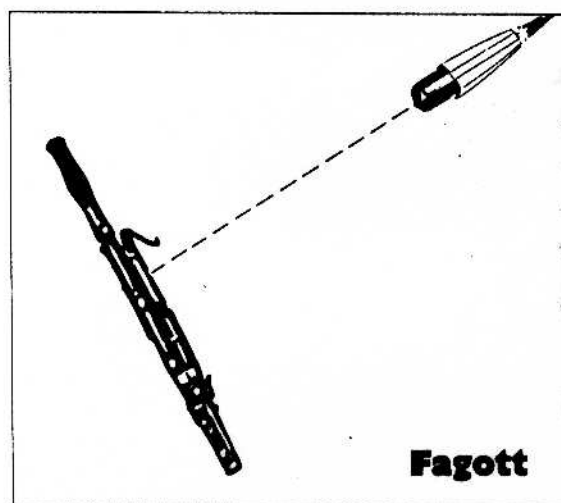
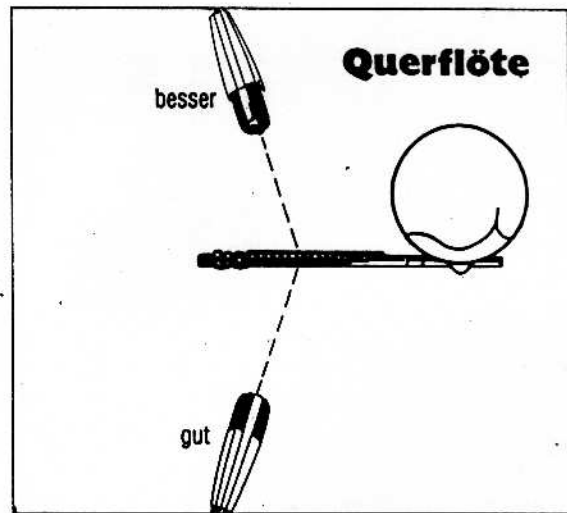
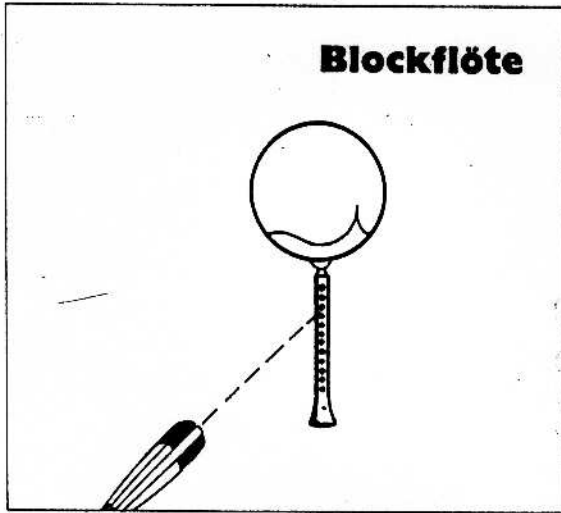

**Trompete  
Flügelhorn**



**Posaune  
Ventilposaune**

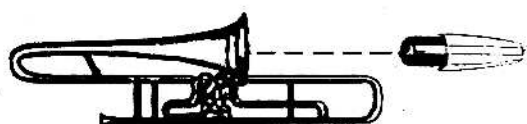

**Waldhorn**

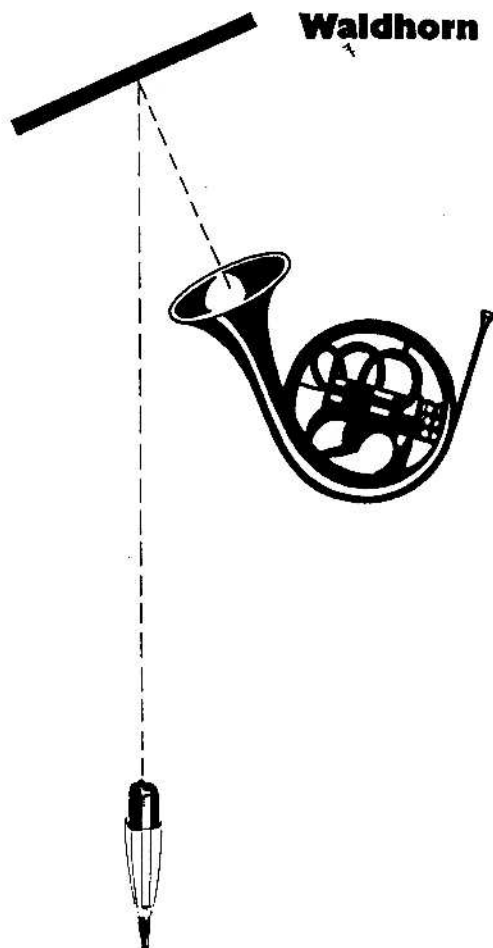

**Baßtuba  
Tenorhorn**

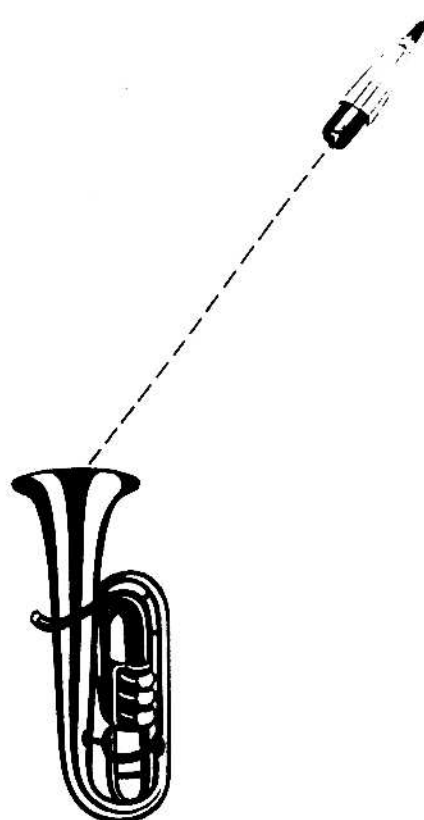

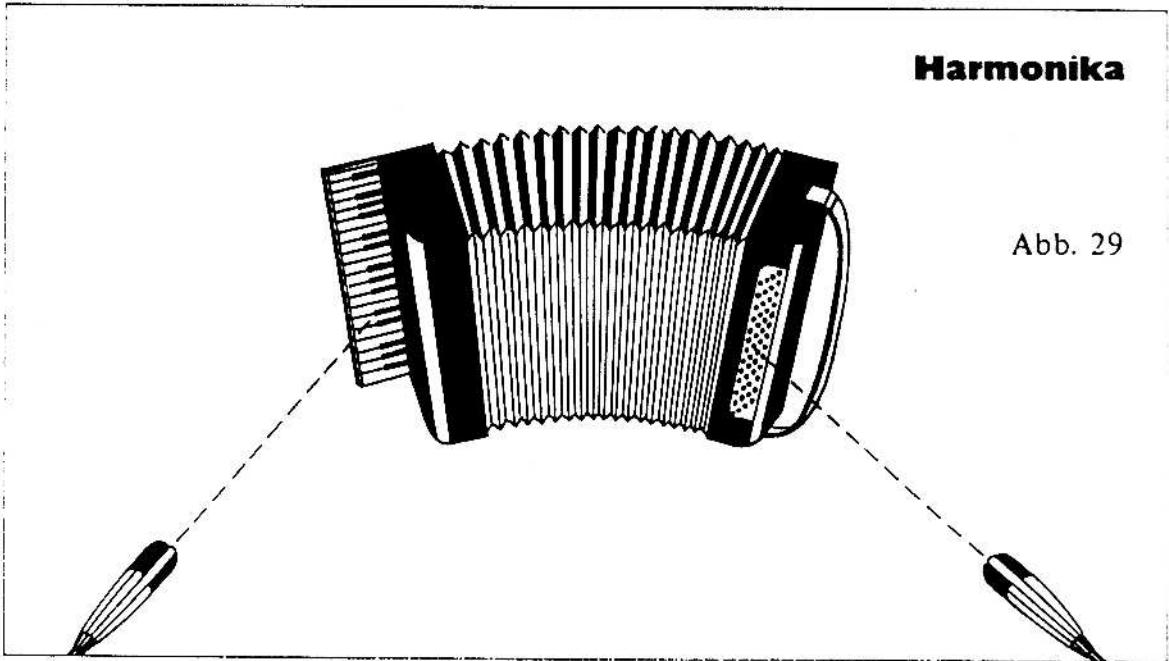
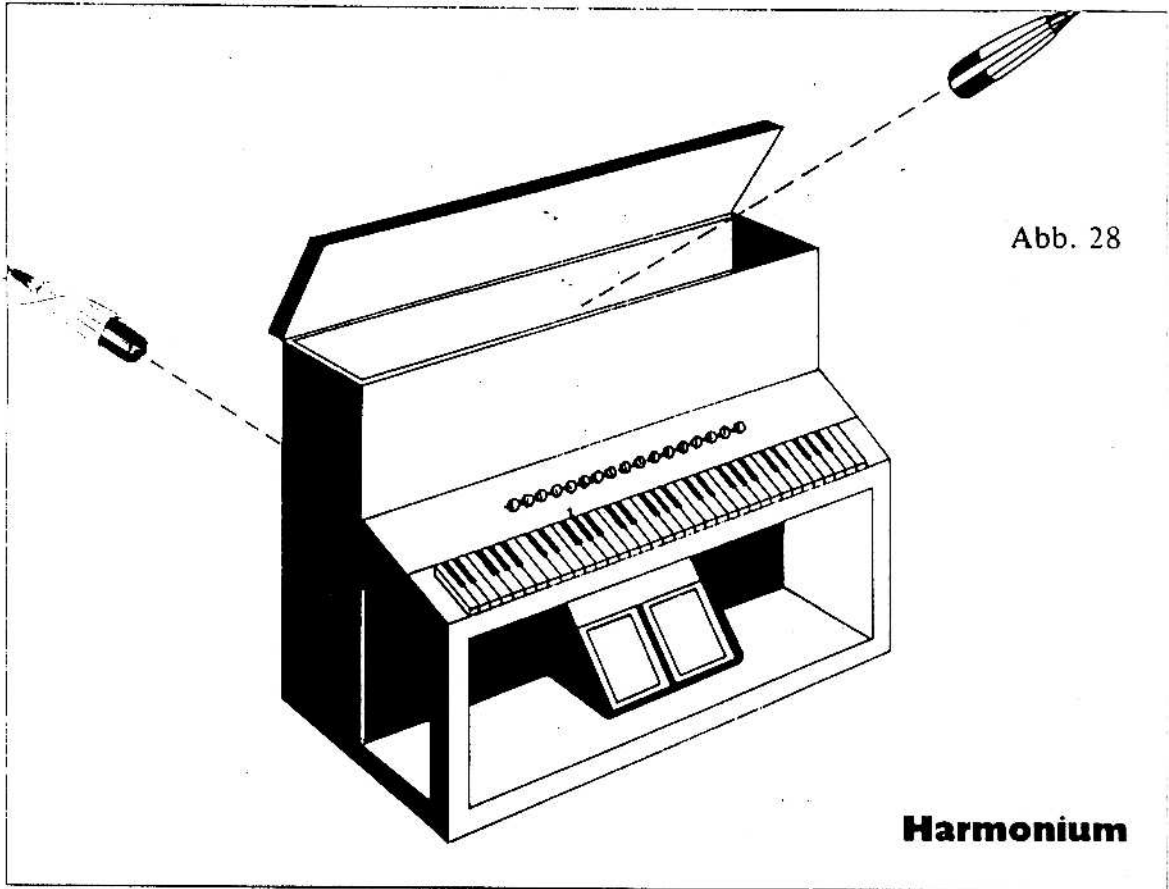

28 und 29 Mehrstimmige Windinstrumente

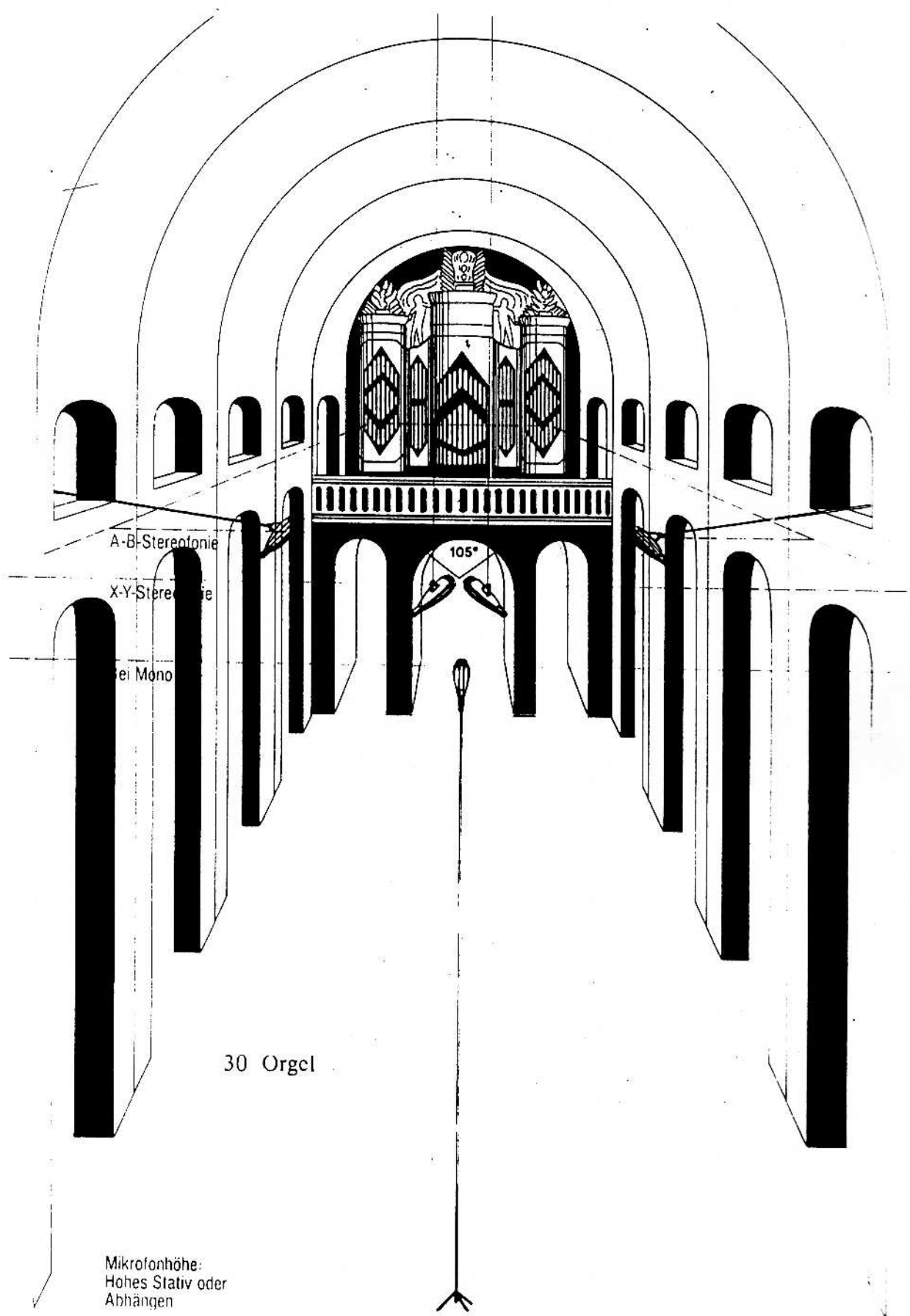

## Streichinstrumente

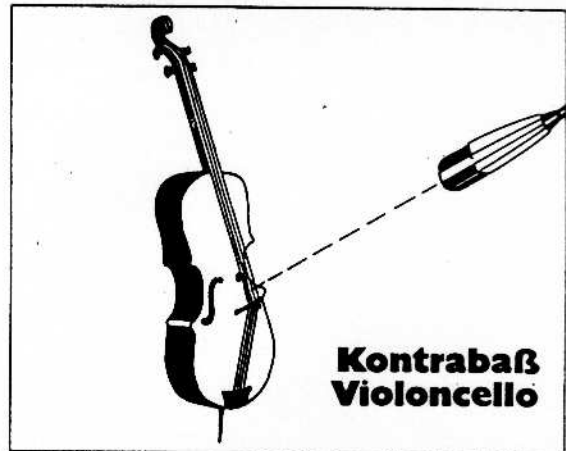
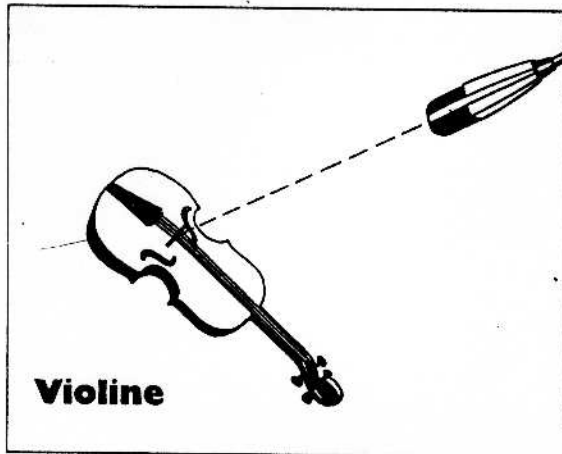

## Zupfinstrumente

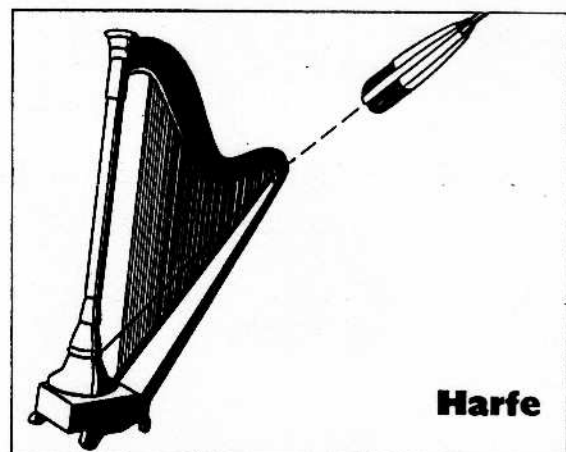
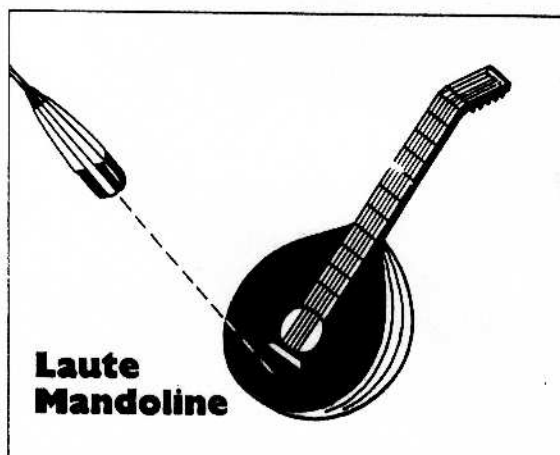
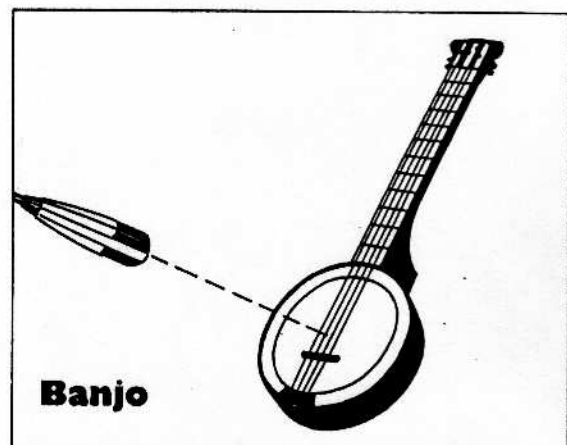
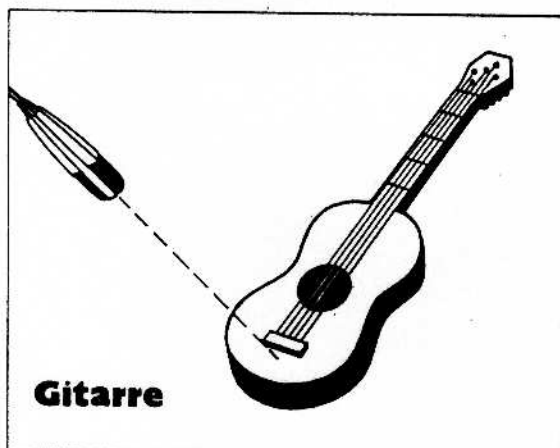

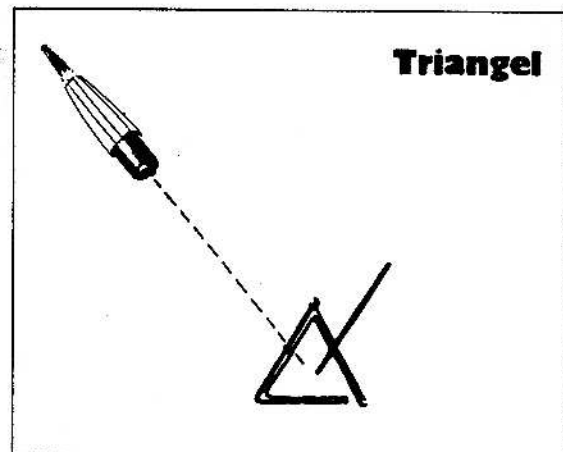
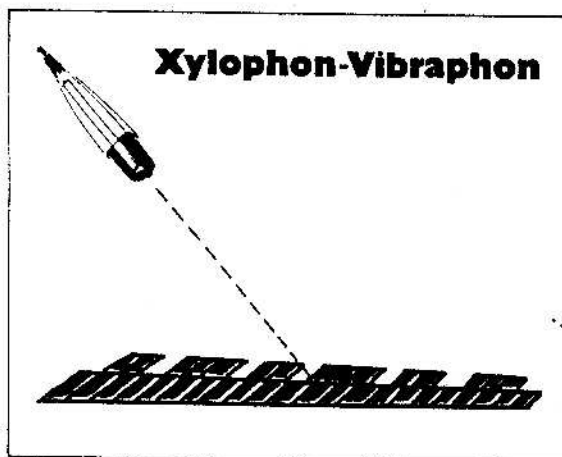
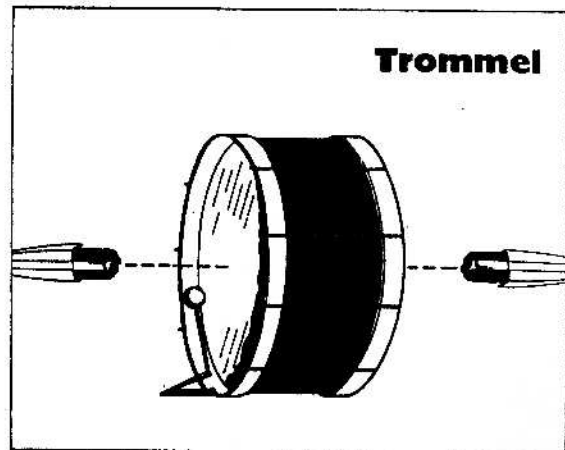
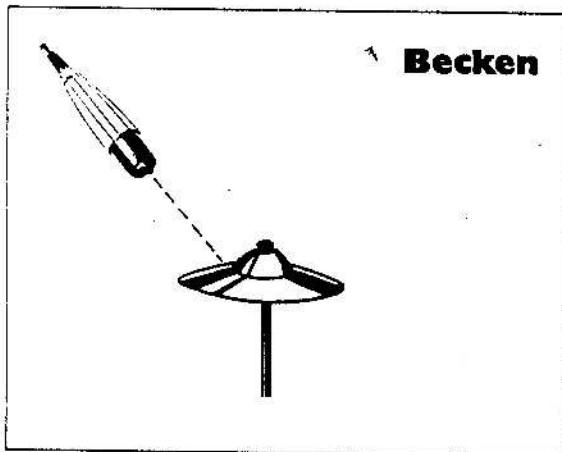
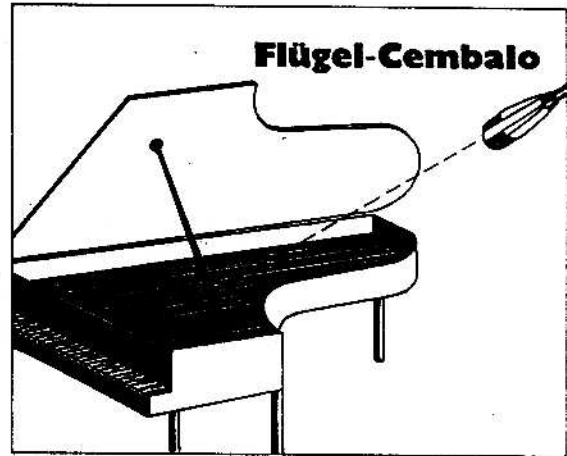
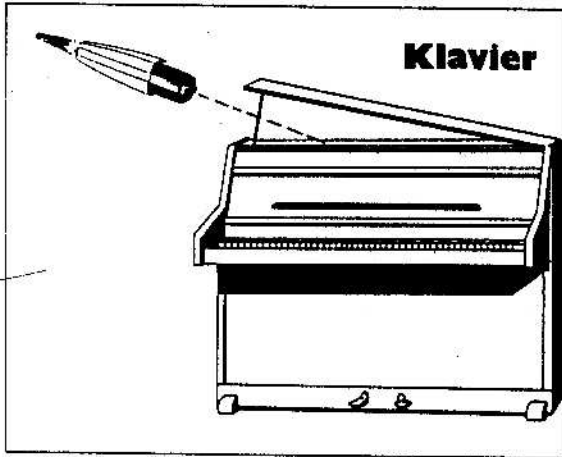



21 Bei der „A-B“-Stereofonie werden zwei gleichartige Mikrofone in einem Abstand von 3-5 m Entfernung voneinander aufgestellt

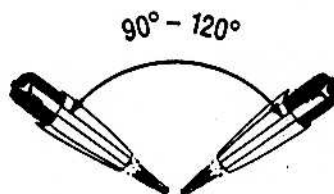
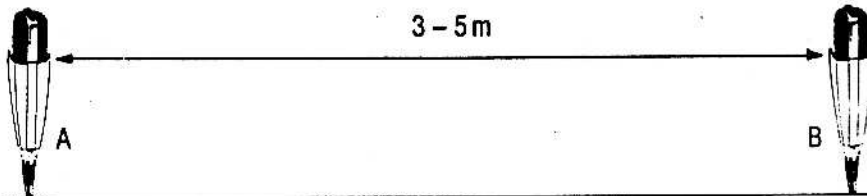
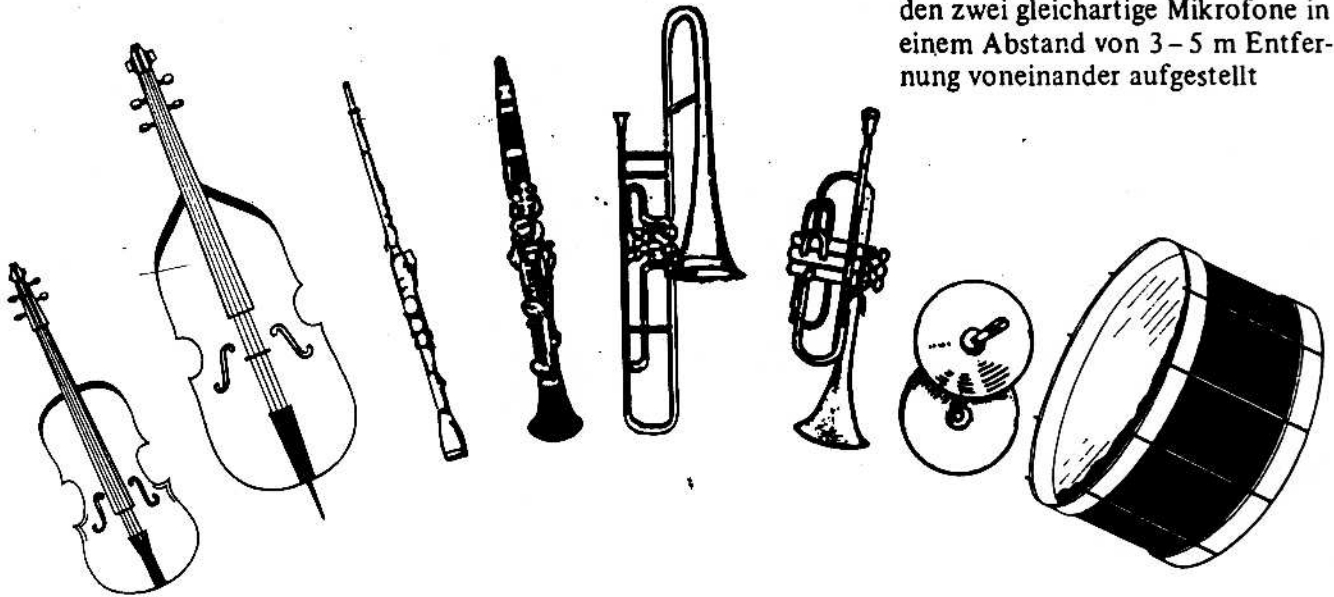

22 „X-Y“-Stereofonie mit zwei gleichartigen Richtmikrofonen. Für Mikrofone mit Nierencharakteristik gilt der größere, für Supernieren der kleinere Winkel

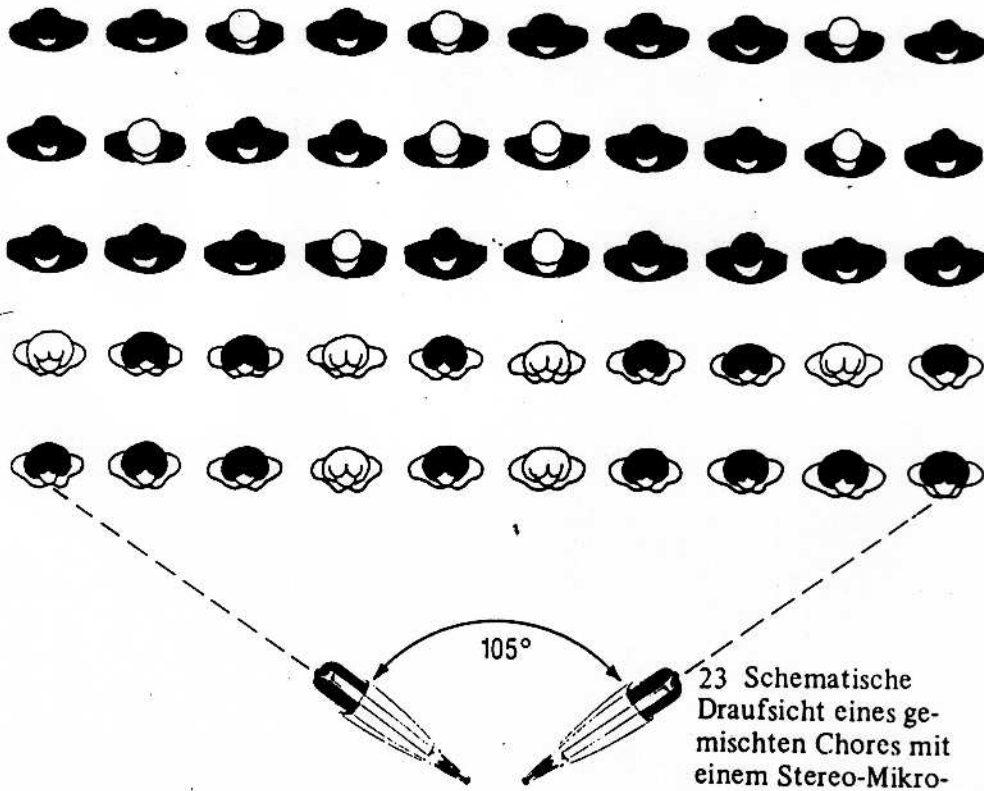

23 Schematische Draufsicht eines gemischten Chores mit einem Stereo-Mikrofonpärchen in 2 m Abstand

24 Schematische Seitenansicht des gemischten Chores mit neuer Mikrofonaufstellung

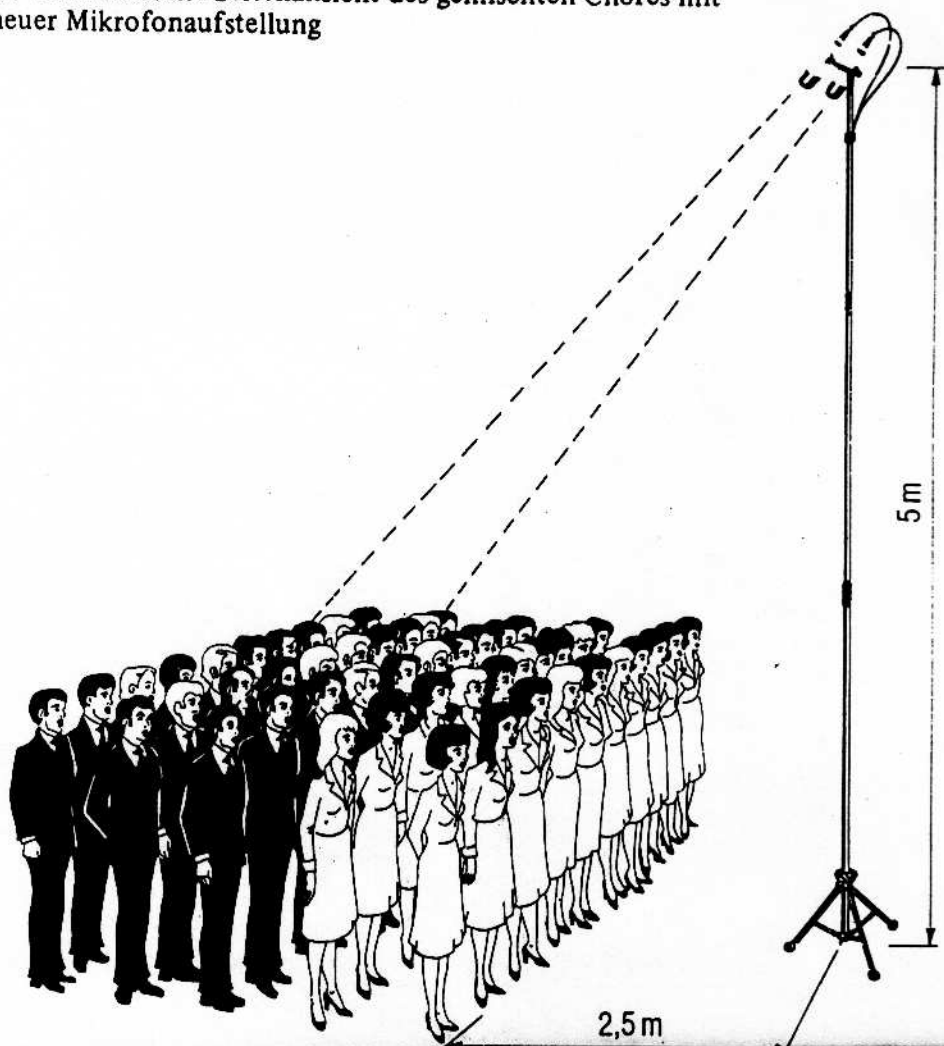

PRISE DE SON  
D'UN SOLISTE AVEC ACCOMPAGNEMENT  
AU PIANO

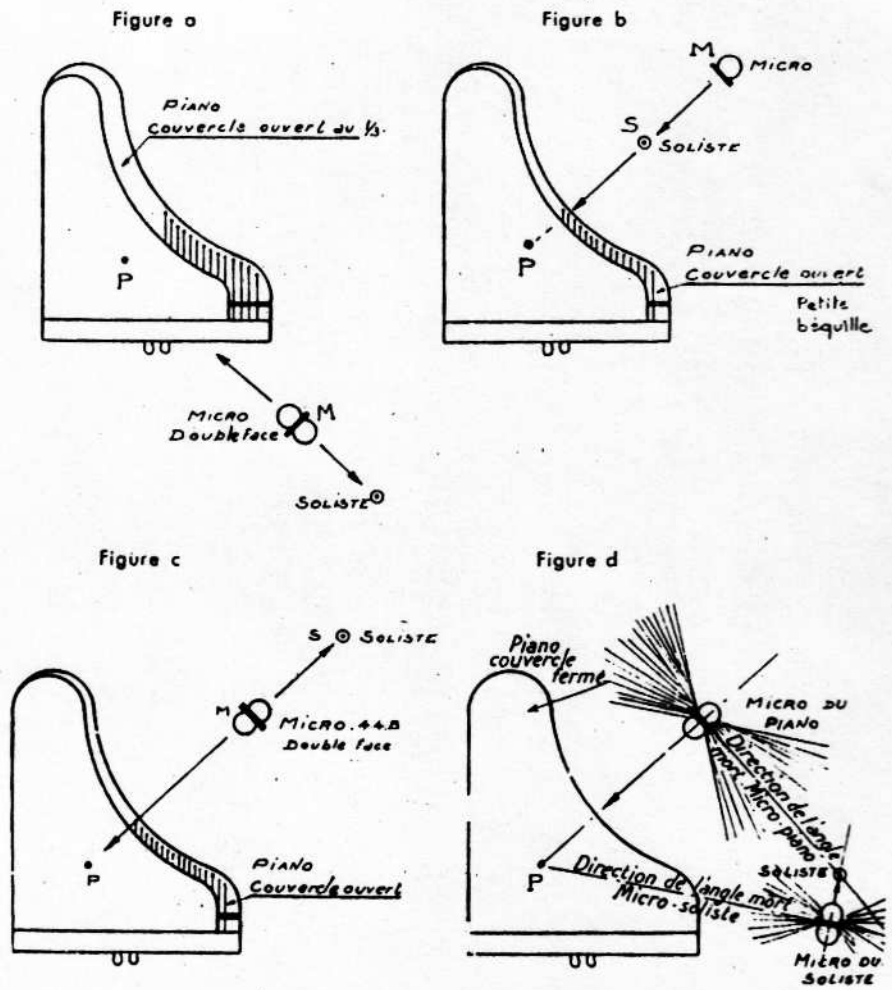

Dans les 3 premiers cas : Le rapport  $\frac{MS}{MP}$  définit l'équilibre :

- Du Soliste par rapport à l'accompagnement.
- Du Plan sonore Soliste par rapport au plan sonore d'accompagnement.

Fig. 10.

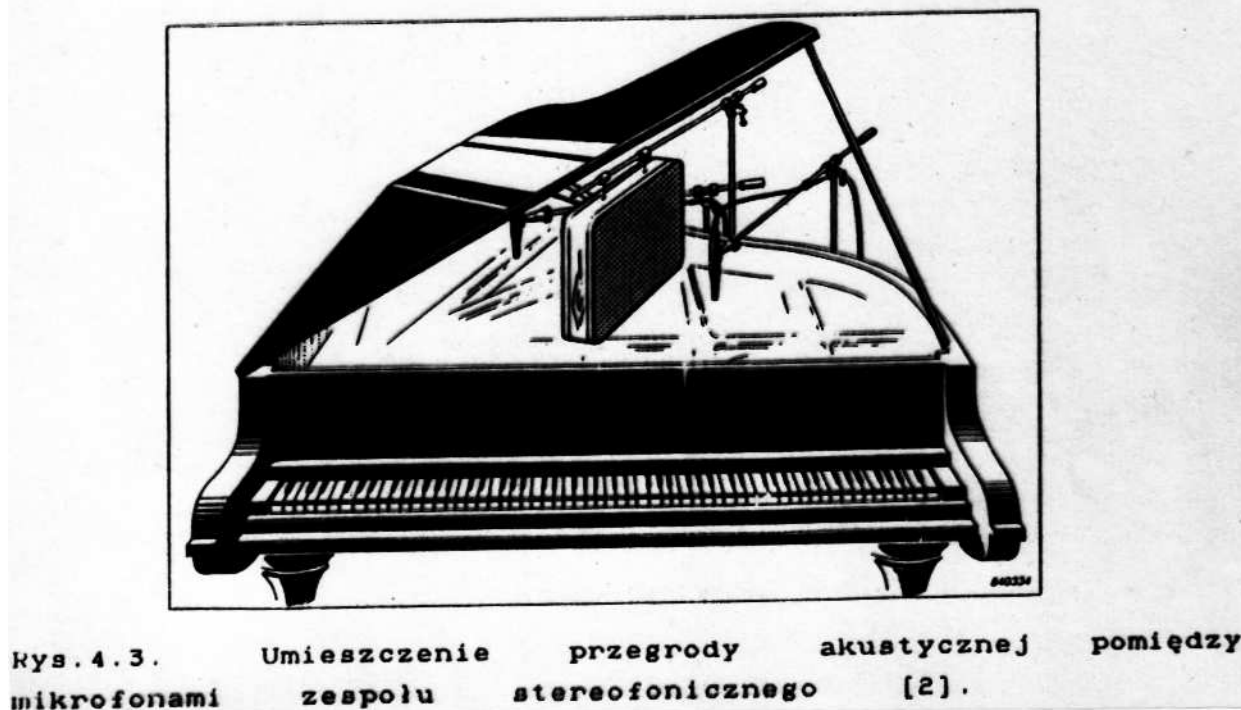
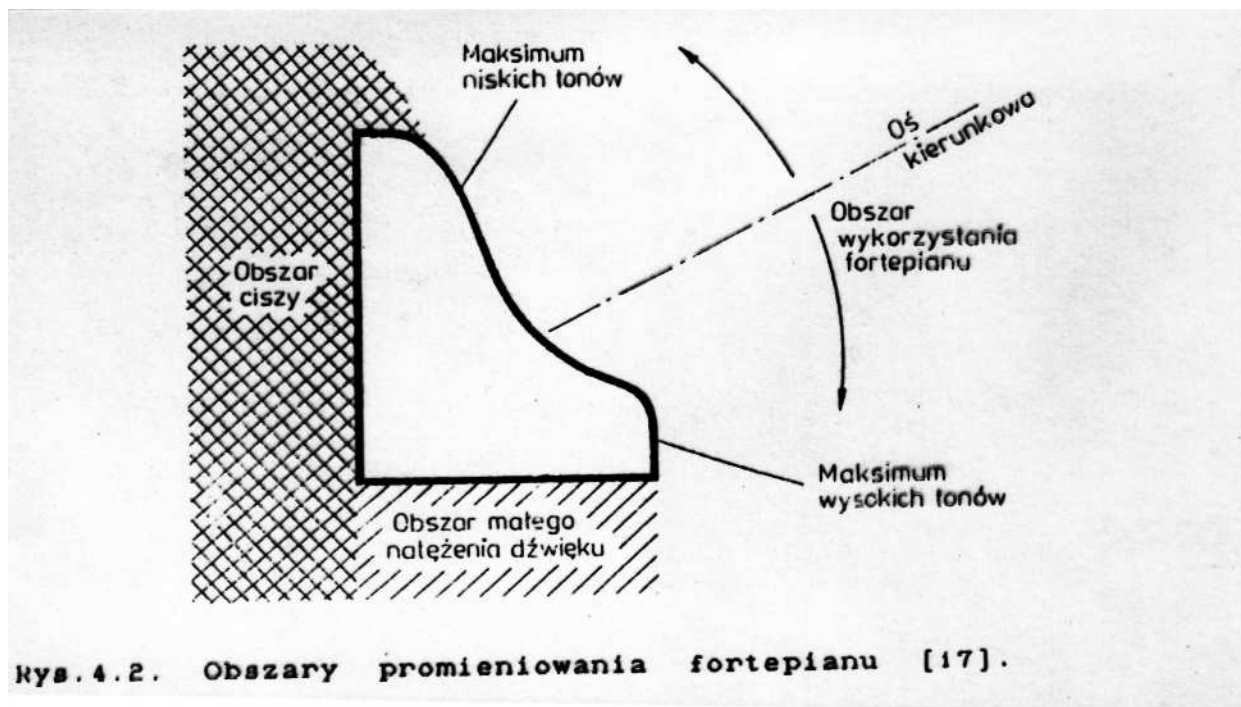

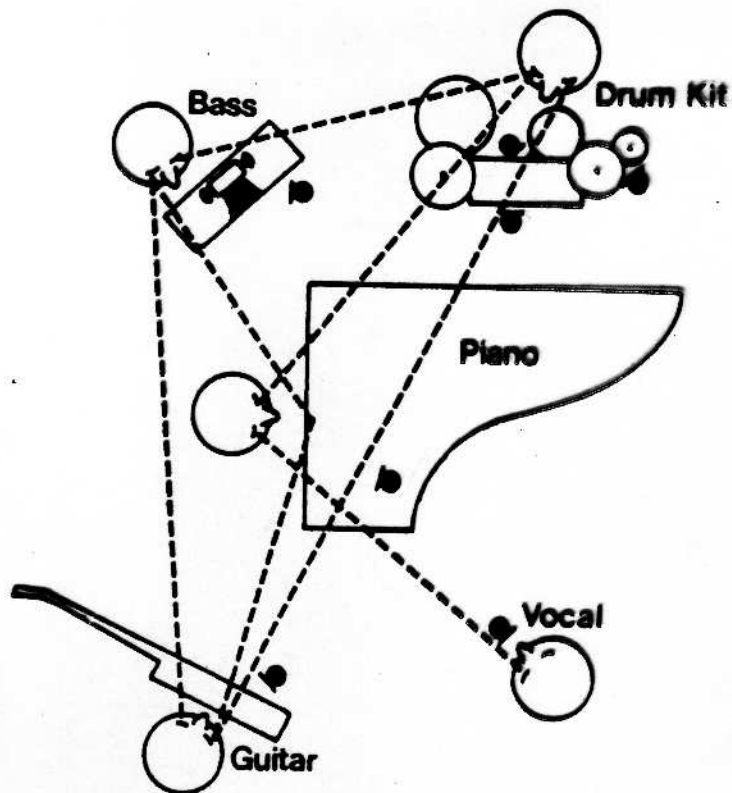

Studio layout. The musicians need to see each other and the microphones placed so as to avoid undue pick-up of other instruments.

218

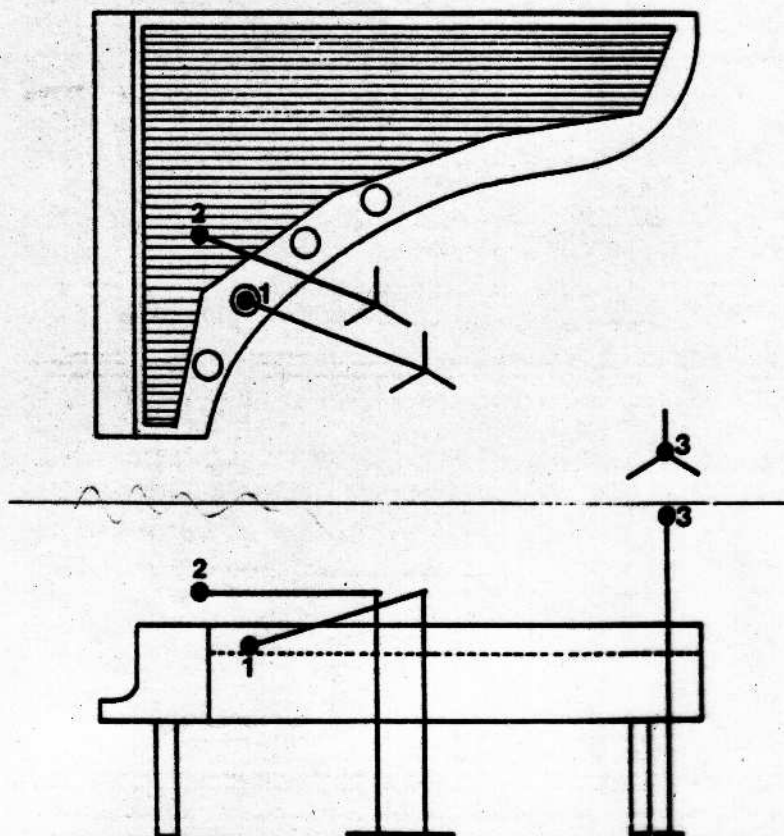

Piano balance. Typical microphonies for different styles of music. 1. Emphasizes percussive quality for pop music and jazz. 2. Broader intermediate position for light music. 3. Full piano sound for recitals and other serious or classical music.

221